



HAL
open science

3D-printed flow system for determination of lead in natural waters

Elodie Mattio, Fabien Robert-Peillard, Catherine Branger, Kinga Puzio, André Margaillan, Christophe Brach-Papa, Joël Knoery, Jean Luc Boudenne, Bruno Coulomb

► **To cite this version:**

Elodie Mattio, Fabien Robert-Peillard, Catherine Branger, Kinga Puzio, André Margaillan, et al.. 3D-printed flow system for determination of lead in natural waters. *Talanta*, 2017, 168, pp.298-302. 10.1016/j.talanta.2017.03.059 . hal-01499475

HAL Id: hal-01499475

<https://amu.hal.science/hal-01499475>

Submitted on 18 Apr 2018

HAL is a multi-disciplinary open access archive for the deposit and dissemination of scientific research documents, whether they are published or not. The documents may come from teaching and research institutions in France or abroad, or from public or private research centers.

L'archive ouverte pluridisciplinaire **HAL**, est destinée au dépôt et à la diffusion de documents scientifiques de niveau recherche, publiés ou non, émanant des établissements d'enseignement et de recherche français ou étrangers, des laboratoires publics ou privés.

3D-printed flow system for determination of lead in natural waters

Elodie Mattio¹, Fabien Robert-Peillard¹, Catherine Branger², Kinga Puzio², André Margailan²,
Christophe Brach-Papa³, Joël Knoery³, Jean-Luc Boudenne¹, Bruno Coulomb^{1*}

¹ Aix Marseille Univ, LCE, UMR 7376, Marseille, France.

² University of Toulon, MAPIEM, La Garde, France.

³ IFREMER, LBCM, Nantes, France.

*Corresponding author: bruno.coulomb@univ-amu.fr

Abstract

The development of 3D printing in recent years opens up a vast array of possibilities in the field of flow analysis. In the present study, a new 3D-printed flow system has been developed for the selective spectrophotometric determination of lead in natural waters. This system was composed of three 3D-printed units (sample treatment, mixing coil and detection) that might have been assembled without any tubing to form a complete flow system. Lead was determined in a two-step procedure. A preconcentration of lead was first carried out on TrisKem Pb Resin located in a 3D-printed column reservoir closed by a tapped screw. This resin showed a high extraction selectivity for lead over many tested potential interfering metals. In a second step, lead was eluted by ammonium oxalate in presence of 4-(2-pyridylazo)-resorcinol (PAR), and spectrophotometrically detected at 520 nm. The optimized flow system has exhibited a linear response from 3 to 120 $\mu\text{g}\cdot\text{L}^{-1}$. Detection limit, coefficient of variation and sampling rate were evaluated at 2.7 $\mu\text{g}\cdot\text{L}^{-1}$, 5.4% (n=6) and 4 sample.h⁻¹, respectively. This flow system stands out by its fully 3D design, portability and simplicity for low cost analysis of lead in natural waters.

Keywords: Lead determination; 3D-printed MPFS system; stereolithography; natural waters

1

2 **1. Introduction**

3 Lead is considered as one of the most toxic heavy metals [1] in the light of its environmental
4 [2] and health [3,4] impacts; it may cause irreversible neurological effects and digestive and
5 kidney malfunctions. Its presence in the environment and more particularly in water can be
6 mainly explained by anthropogenic sources like paints, arms and electronic [5] industries
7 products. For these reasons, the World Health Organization has identified lead as one of the 10
8 chemicals of major public health concern [6] and has recommended a guideline value of 10
9 $\mu\text{g.L}^{-1}$ of lead in drinking water. It is therefore necessary to quantify lead by a rapid and efficient
10 method to avoid toxic consumption.

11 Many methods are already available for lead determination such as spectrophotometry [7],
12 voltammetry [8,9], graphic furnace atomic absorption spectrometry [10], or inductively coupled
13 plasma spectroscopy [11,12], but they require costly and sophisticated devices and do not allow
14 real-time and on-site measurements. In this context, mesofluidic and microfluidic systems can
15 help to meet these needs thanks to their intrinsic advantages: miniaturization and low energy
16 consumption, decreased reagents consumption and waste generation. Flow analysis offers many
17 opportunities [13,14] and Flow Injection Analysis (FIA), Sequential Injection Analysis (SIA)
18 or MultiSyringe Flow Injection Analysis (MSFIA) based systems have been successfully
19 applied for the determination of a wide range of substances in environmental matrices. Among
20 flow analysis system, pulse flow systems using solenoid diaphragm micropumps (MPFS: Multi
21 Pumping Flow System) present high flexibility, easy configuration and low cost. Another
22 advantage is that the signal peaks are higher compared to other flow techniques, due to
23 turbulences created by pump diaphragm strokes, which improve mixing between reagents and
24 sample [15]. Recently, such MPFS systems were developed for phosphorous [16] or boron [17]
25 determination in aqueous samples.

1 Several units can be combined to create a flow system in full compliance with the analytical
2 needs: solid phase extraction for pre-concentration, photo-oxidation or digestion, membrane or
3 membrane-less separation, detection and many others. To increase versatility and ease of
4 fabrication of flow systems, 3D printing is increasingly used in flow analysis [18,19]. This
5 printing technology can be divided into three main categories: Fused Deposition Modeling
6 (FDM) where a thermoplastic material is heated and extruded from a XYZ positionable nozzle,
7 Multi Jet Modeling (MJM) which is based on an inkjet head to deposit liquid photopolymer
8 (plastic resin or casting wax) layer by layer and finally stereolithography (SL) [20] invented in
9 the 1980s and which is a layer manufacturing process with liquid materials [21] as MJM. SL is
10 based on a mobile platform which dives in a resin tray, where a laser polymerizes the resin layer
11 by layer. The most frequently used material is poly(methyl methacrylate) (PMMA) which
12 allows to decrease fabrication cost and improve resolution [22]. 3D-printing technologies
13 emergence enables creation of new type of units [23,24] for microfluidic systems which can be
14 imagined and combined according to the analytical needs.

15 In this paper, the development of a novel 3D-printed multi-pumping flow system for the
16 determination of lead in natural waters is presented. The system is composed of three 3D-
17 printed units: a resin column for lead solid phase extraction, a mixing coil and a classical flow
18 cell for UV-Spectroscopy. The 3 modules are connected to one another by a screw system to
19 limit tubings between the three units. Lead solid phase extraction is based on a commercial
20 crown-ethers resin (TrisKem Pb resin) and the chromogenic reagent used for the
21 spectrophotometric detection of lead is 4-(2-pyridylazo)resorcinol (PAR). The system was
22 applied to the determination of lead in real river water samples.

23

24 **2. Materials and methods**

25 2.1. Reagents and samples

1 All chemicals used were of analytical grade and used without further purification. Solutions
2 were prepared with ultra-pure water (Millipore, resistivity > 18 MΩ cm) and stocked in high
3 density polyethylene flasks. Lead standard solutions were prepared by dilution of a commercial
4 1 g.L⁻¹ AAS lead stock solution (Fisher Chemical, USA) and stabilized with 1% v/v nitric acid
5 trace metal grade (Fisher Chemical, USA). A multi-metal solution (0.037 mmol.L⁻¹ for each
6 metal) was prepared by dissolving appropriate amounts of lead nitrate and cadmium nitrate
7 (Alfa Aesar, USA), nickel nitrate and copper nitrate (Merck, Germany), iron (III) sulphate and
8 potassium chromate (VI) (Prolabo, France), cobalt nitrate, zinc nitrate, and aluminium chloride
9 (Sigma-Aldrich, USA) in ultra-pure water.

10 The commercial TrisKem Pb Resin (PB-B25-S, 50-100μm, TrisKem, France) was used for lead
11 extraction. The elution solution was prepared from ammonium oxalate (Prolabo, France). For
12 detection, a 0.01 mmol.L⁻¹ solution of 4-(pyridyl-2-azo)-resorcinol (PAR) monosodium salt
13 (Merck, Germany) was prepared in a 1 mmol.L⁻¹ borate buffer solution (pH = 12).

14 Freshwater samples were collected at purposely chosen points in a coastal river “The Arc” in
15 the south-east of France, near industrial or urban effluents discharge points. All samples were
16 UV-photo-oxidized with a 254 nm low-pressure mercury lamp (UVP PenRay, USA) during 30
17 minutes before analysis allowing liberation of lead linked to natural organic ligands, inorganic
18 ligands or even to anthropogenic organic ligands.

19

20 2.2.Apparatus

21 2.2.1. Flow system

22 The three units of the MPFS system (Fig. 1) were designed with Rhinoceros® 5.0 3D software
23 (Robert McNeel & Associates Europe, Spain), then printed with a poly(methyl methacrylate)
24 resin on the 3D printer Form1+ (Formlabs, USA). The first unit consisted of a resin column,
25 tightly closed by a screw piece with three entry channels for injection of sample and reagents.

1 The resin was packed in this unit between two layers of glass wool. To optimize mixing of
2 eluate and chromogenic reagent used for lead detection (PAR), a second unit composed of a
3 serpentine mixing coil (1.5 mm internal diameter, 50 cm length) and of a connection for PAR
4 inlet was added to the system. Finally, the detection step was performed with a classical
5 spectroscopic flow-cell with a 5-cm optical pathlength. Sample and reagents were introduced
6 inside the system by means of four solenoid micro-pumps (Bio-ChemValve Inc., USA) that had
7 a stroke volume of 20 μL and a high frequency of 250 cycles/min. These pumps were computer-
8 controlled by a MCFIA/MPFS system (Sciware, Spain) with eight digital 12V output channels.
9 For the detection, two FC-UV600 optical fibres (Ocean Optics, USA) were connected at the
10 ends of the optical pathlength, and isolated from the reaction mixture with two tailor-made
11 quartz discs, to guide the light from the source to the spectrophotometric detector. The radiation
12 of the halogen bulb of a DH-2000 UV-Vis light source (Ocean Optics, USA) was transmitted
13 to a USB2000 miniature spectrometer detector (Ocean Optics, USA). The whole system was
14 controlled by AutoAnalysis 5.0 software (Sciware, Spain).

15

16 2.2.2. Metal analysis

17 Graphite furnace atomic absorption spectrometry (GF-AAS) was used to optimize the
18 extraction/elution steps on TrisKem Pb resin and validate lead amounts in real samples (after
19 filtration on a 0.45 μm polyethersulfone membrane). The measurements were carried out on a
20 Thermo Scientific ICE3500 (USA) atomic absorption spectrometer equipped with a lead
21 hollow-cathode lamp operated at 10 mA (wavelength of 217 nm). Argon flow was 0.2 $\text{L}\cdot\text{min}^{-1}$
22 except during atomisation step (no flow). The furnace settings were: drying at 110 $^{\circ}\text{C}$, ramp for
23 9 s, hold for 35 s; cracking at 800 $^{\circ}\text{C}$, ramp for 5 s, hold for 20 s; atomising at 1200 $^{\circ}\text{C}$, ramp
24 for 1 s and 3 s hold; cleaning at 2500 $^{\circ}\text{C}$, no ramp and 3 s hold.

1 Interfering cations were determined by inductively coupled plasma–atomic emission
2 spectrometry (ICP–AES) with a Jobin YVON JY2000 Ultratrace spectrometer, equipped with
3 a CMA spray chamber and a Meinhard R50-C1 glass nebuliser. Determinations were performed
4 with the following settings: power 1000W, pump speed 20 mL.min⁻¹, plasma flow rate 12
5 L.min⁻¹, coating gas flow rate 0.2 L.min⁻¹, nebuliser flow rate 0.9 L.min⁻¹ and nebuliser
6 pressure 2.08 bar.

7

8 2.3.Flow procedure

9 The MPFS system was operated according to the procedure in 6 steps given in Table 1: in step
10 1, 9 mL of nitric acid solution (0.05 mol.L⁻¹) was used for conditioning the Pb resin and washing
11 the system before analysis. Then 50 mL of acidified sample were introduced in the system (step
12 2). In step 3, the resin was washed again with nitric acid solution (0.05 mol.L⁻¹) to eliminate
13 potential interfering species extracted by the resin. 5 mL of ammonium oxalate solution (0.025
14 mol.L⁻¹) and PAR (0.01 mmol.L⁻¹) were simultaneously pumped through the resin to eluate
15 extracted lead and at the inlet of the mixing coil, respectively (steps 4-5).

16 Measurements were based on the peak height. The analytical signal was recorded at 520 nm
17 when the elution started. Absorbance spectra were acquired every 0.5 s, with an integration
18 time of 55 ms and an average of 3 spectra.

19

20 3. Results and discussion

21 3.1.Extraction and washing steps

22 3.1.1. Influence of concentration of nitric acid

23 The developed system was based on the spectrophotometric determination of lead in the
24 presence of PAR reagent. However, it is well known that lead determination by this simple
25 method often suffers from interferences of cadmium, copper and zinc [25]. Therefore, the

1 concentration of these interfering metals should be reduced before PAR detection to allow
2 selective determination of lead.

3 Lead determination was thus based on extraction properties of the resin TrisKem Pb resin. This
4 resin was initially developed for the separation of ^{210}Pb and ^{210}Po and is constituted by crown-
5 ethers diluted in isodecanol and impregnated on an inert support. The length of the carbon chain
6 of isodecanol facilitates lead elution. Its retention capacity is 29 mg Pb/g of resin. The
7 manufacturer's instructions recommend acidification of samples with 1 mol.L⁻¹ nitric acid
8 before extraction of lead on TrisKem Pb resin. However, the first experiments carried out with
9 1 mol.L⁻¹ nitric acid led, after a few injections, to yellowing and cracking of the inlet of 3D-
10 printed column part. The effect of HNO₃ concentration on the extraction of lead and potentially
11 interfering metals was thus tested in the range 0-0.1 mol.L⁻¹ in order to preserve 3D-printed
12 parts.

13 The results in Fig. 2 showed that more than 90% of lead was extracted with HNO₃ concentration
14 above 0.02 mol.L⁻¹. The best lead extraction (97%) was obtained with HNO₃ 0.1 mol.L⁻¹.

15 Concerning the other metal cations, iron was also partially extracted (20-50%, with the highest
16 extraction at 0.1 mol.L⁻¹). Aluminium, copper and zinc were not retained by the resin whatever
17 the acid concentration. For HNO₃ concentrations of 0.02 and 0.05 mol.L⁻¹, a very few amount
18 ($\leq 5\%$) of cobalt, chromium, and cadmium was extracted. It can therefore be concluded that the
19 resin has an excellent selectivity for lead over other metals, except for iron for which extraction
20 is dependent on HNO₃ concentration. A nitric acid concentration of 0.05 mol.L⁻¹ appeared to
21 be sufficient to extract lead quantitatively and to limit the extraction rate of iron below 20%.

22 After metal extraction on the resin, a washing step can improve the selectivity by removing
23 potentially interfering metals without eluting the analyte of interest. This washing step has also
24 been studied with different HNO₃ concentrations. Based on the previous results, only iron and
25 lead were studied. The washing solutions were collected and analysed by ICP-AES. As can be

1 seen in Fig. 3 the amount of both iron and lead washed out decreased with increasing HNO₃
2 concentration. With HNO₃ 0.02 mol.L⁻¹, all the iron retained within the resin was eliminated,
3 but an important lead elution rate of 42% was also observed. A nitric acid concentration of 0.05
4 mol.L⁻¹ seems to be the best compromise between iron elimination (75%) and limited lead
5 elution rate (about 10%).
6 To summarize 0.05 mol.L⁻¹ HNO₃ may be used for both extraction and washing steps, thereby
7 limiting the number of pumps to be used in the system.

8

9 3.1.2. Sample flow-rate

10 Sample flow rate was studied from 2 to 5 mL.min⁻¹ for a sample volume of 30 mL. Samples
11 were acidified with 0.05 mol.L⁻¹ HNO₃ before extraction. As displayed in supplementary
12 material (Fig. S1), results showed an important increase of lead extraction from 3 mL.min⁻¹ to
13 5 mL.min⁻¹. At the highest flow rate (5 mL.min⁻¹) the extraction percentage of lead reached 94
14 %.

15 To avoid overpressure problem of solenoid pumps or clogging of resin column, the column
16 inner diameter and height has been set respectively at 7.8 mm and 4.5 mm, which are higher
17 than in a traditional packed column. None of the previously mentioned problems were observed
18 during analysis. Although solenoid pumps are not usually suitable for resin solid phase
19 extraction, it seems that high sample flow rates enable fluidizing of the resin bed and thus good
20 lead extraction. Therefore, a 5mL.min⁻¹ flow rate was chosen for the system.

21

22 3.2. Elution step

23 Ammonium oxalate is recommended by the resin manufacturer for lead elution. The lead
24 elution has thus been studied at different concentrations of ammonium oxalate. The elution flow
25 rate has been adjusted at 4 mL.min⁻¹, according to the resin manufacturer instructions.

1 The results shown in Fig. 4 highlighted that elution efficiency increased with ammonium
2 oxalate concentration up to 0.05 mol.L^{-1} .

3 For concentration of ammonium oxalate between 0.025 and 0.1 mol.L^{-1} , the results obtained
4 were not significantly different. To limit reagent consumption, the concentration of ammonium
5 oxalate was adjusted at 0.025 mol.L^{-1} for further experiments.

6

7 3.3. Detection

8 Lead elution profile has been studied by collecting small fractions (0.5 mL) of ammonium
9 oxalate used for elution with a flow rate of 5 mL.min^{-1} . As can be seen on Fig.S2
10 (Supplementary material), elution was complete within one minute (elution rate of 99% of total
11 extracted lead after 5 mL).

12 Lead was detected by spectrophotometry using a PAR solution pumped simultaneously and
13 mixed with ammonium oxalate in the mixing coil. PAR solution was buffered with borate
14 solution at $\text{pH}=12$ in order to obtain a mixture at $\text{pH}=9$ (optimised for UV-Vis detection) when
15 mixed with ammonium oxalate which pH is around 6.6 .

16 PAR reagent and ammonium oxalate flow rates were studied from 1 to 5 mL.min^{-1} .
17 Optimization was carried out with a standard lead solution of $100 \mu\text{g.L}^{-1}$. PAR flow rate was
18 optimized using a fixed ammonium oxalate flow rate of 5 mL.min^{-1} and inversely. Fig. 5 showed
19 that the best absorbance was obtained with the maximum flow rate of the pumps useable for
20 the two reagents (5 mL.min^{-1}). The absorbance increased regularly with increasing PAR flow
21 rate. The absorbance values increased slightly with an ammonium oxalate flow rate between 1
22 and 4 mL.min^{-1} and, strongly increased for a flow rate of 5 mL.min^{-1} . This observation was
23 consistent with results obtained for sample flow rate with better efficiency at high flow rates.
24 However, eluent flow rate seemed to have less influence than sample flow rate. Flow rates of
25 PAR and ammonium oxalate were thus fixed at 5 mL.min^{-1} .

1

2

3.4. Analytical features

3

Calibration curves have been constructed for various sample volumes (10, 25 and 50 mL). From

4

these data, limits of detection (LOD; 3σ ; $n=10$) and coefficient of variation (CV; $n=6$) were

5

determined and summarized in Table S1 (Supplementary material). The analytical features

6

obtained for a 50 mL sample volume seemed adapted for typical lead concentrations in natural

7

waters: LOD was calculated at $2.7 \mu\text{g.L}^{-1}$, linear domain range was between 3 and $120 \mu\text{g.L}^{-1}$.

8

The LOD was acceptable for environmental sample analysis, but sample volume can potentially

9

be increased if lower LOD needs to be reached for water samples with very small amounts of

10

lead. An additional experiment has been carried out and a volume of 200 mL of sample has

11

been passed through the TrisKem Pb resin column. The results obtained showed that no traces

12

of lead were detected at the column outlet and that the breakthrough volume of the resin was

13

not reached. Coefficient of variation obtained with the optimal conditions (50 mL sample

14

volume), for a lead concentration of $50 \mu\text{g.L}^{-1}$ was 5.4 %.

15

A brief comparison of previously reported flow methods for lead determination with proposed

16

3D-printed flow system is given in Table 2. Some of these methods require complicated or

17

expensive equipment in particular for detection step [26,27,29,30]. Compared to other simpler

18

flow procedures using spectrophotometric detection [28,31], the proposed method has a lower

19

detection limit better suited for analysis of natural water samples.

20

21

3.5. Validation

22

In order to validate the 3D-printed optimized system, five samples of freshwater have been

23

collected at purposely chosen points in a coastal river ("The Arc", south of France) in areas

24

close to anthropogenic activities. The samples were UV-photooxidized at 254 nm during 30

25

minutes and filtered at $0.45 \mu\text{m}$ before analysis. These samples have been analyzed in duplicate

1 by ICP-AES and developed 3D-printed system with a sample volume of 50 mL, and the results
2 were summarized in Table 3.

3 The values obtained by the two methods were consistent. The mean difference between the two
4 methods was 5.8%, (min -11.2%; max 11.7%). The results obtained by the proposed system
5 were compared (*t* test) with the reference method values (ICP-AES) and no significant
6 differences at the 95% confidence level were found.

7

8 **4. Conclusion**

9 A 3D-printed system was developed for determination of lead in natural waters. Lead
10 quantification was based on the selective solid phase extraction of lead on TrisKem Pb resin
11 followed by elution with ammonium oxalate and spectrophotometric detection using 4-(2-
12 pyridylazo)-resorcinol as chromophoric reagent. Interferences were eliminated by optimisation
13 of extracting and washing steps on TrisKem Pb resin. Detection limit obtained ($2.7 \mu\text{g.L}^{-1}$) was
14 consistent with environmental samples analysis but sample volume may be increased if lower
15 detection limits are needed. The proposed flow system was compared to a reference method
16 (ICP-AES) and was satisfactorily applied to natural waters samples. The optimized 3D-printed
17 MPFS flow system could be controlled by an open-source microcontroller board to design a
18 low cost portable on-line analyzer [16,17].

19

20 **Acknowledgment**

21 This work was included in the project “Lab-on-Ship” funded by the French Research Agency
22 (ANR-14-CE04-0004).

23

24 **References**

25

- 1 [1] R. Garnier, Toxicité du plomb et de ses dérivés, EMC - Toxicologie-Pathologie. 2 (2005)
2 67–88.
- 3 [2] M. Dikilitas, S. Karakas, P. Ahmad, Chapter 3 - Effect of Lead on Plant and Human DNA
4 Damages and Its Impact on the Environment, in: Plant Metal Interaction, Elsevier, 2016: pp.
5 41–67.
- 6 [3] D.R. Juberg, Lead and human health: An update, Am Cncl on Science, Health, 2000.
- 7 [4] F.M. Johnson, The genetic effects of environmental lead, Mutation Research 410 (1998)
8 123–140.
- 9 [5] M. Pecht, Y. Fukuda, S. Rajagopal, The impact of lead-free legislation exemptions on the
10 electronics industry, IEEE Transactions on Electronics Packaging Manufacturing 27 (2004)
11 221–232.
- 12 [6] World Health Organization | Lead poisoning and health, WHO.
13 <http://www.who.int/mediacentre/factsheets/fs379/en/> (accessed November 10, 2016).
- 14 [7] I. Rahman, Y. Furusho, Z. Begum, R. Sato, H. Okumura, H. Honda, H. Hasegawa,
15 Determination of lead in solution by solid phase extraction, elution, and spectrophotometric
16 detection using 4-(2-pyridylazo)-resorcinol, Central European Journal of Chemistry 11 (2013)
17 672-678.
- 18 [8] H. Fang, F. Tang, J. Shi, H. Zheng, L. Bi, W. Wang, Determination of trace lead and
19 cadmium using stripping voltammetry in fluidic microchip integrated with screen-printed
20 carbon electrodes, Instrumentation Science & Technology 40 (2012) 590–602.
- 21 [9] G. Abate, J.C. Masini, Complexation of Cd (II) and Pb (II) with humic acids studied by
22 anodic stripping voltammetry using differential equilibrium functions and discrete site
23 models, Organic Geochemistry 33 (2002) 1171–1182.

- 1 [10] K.W. Bruland, K.H. Coale, L. Mart, Analysis of seawater for dissolved cadmium, copper
2 and lead: An intercomparison of voltammetric and atomic absorption methods, *Marine*
3 *Chemistry* 17 (1985) 285–300.
- 4 [11] T.-Y. Ho, C.-T. Chien, B.-N. Wang, A. Siriraks, Determination of trace metals in
5 seawater by an automated flow injection ion chromatograph pretreatment system with
6 ICPMS, *Talanta* 82 (2010) 1478–1484.
- 7 [12] M. Zougagh, A. García de Torres, E. Vereda Alonso, J.M. Cano Pavón, Automatic on
8 line preconcentration and determination of lead in water by ICP-AES using a TS-
9 microcolumn, *Talanta* 62 (2004) 503–510.
- 10 [13] V. Cerdà, J.M. Estela, R. Forteza, A. Cladera, E. Becerra, P. Altimira, P. Sitjar, *Flow*
11 *techniques in water analysis*, *Talanta* 50 (1999) 695–705.
- 12 [14] M. Trojanowicz, *Advances in Flow Analysis*, John Wiley & Sons, 2008.
- 13 [15] J.L.M. Santos, M.F.T. Ribeiro, A.C.B. Dias, J.L.F.C. Lima, E.E.A. Zagatto, Multi-
14 pumping flow systems: The potential of simplicity, *Analytica Chimica Acta* 600 (2007) 21–
15 28.
- 16 [16] P. González, N. Pérez, M. Knochen, P. González, N. Pérez, M. Knochen, Low cost
17 analyzer for the determination of phosphorus based on open-source hardware and pulsed
18 flows, *Química Nova* 39 (2016) 305–309.
- 19 [17] P. González, A. Sixto, M. Knochen, Multi-pumping flow system for the determination
20 of boron in eye drops, drinking water and ocean water, *Talanta* 166 (2017) 399-404.
- 21 [18] N. Bhattacharjee, A. Urrios, S. Kang, A. Folch, The upcoming 3D-printing revolution
22 in microfluidics, *Lab on a Chip* 16 (2016) 1720–1742.
- 23 [19] A.K. Au, W. Huynh, L.F. Horowitz, A. Folch, 3D-Printed Microfluidics, *Angewandte*
24 *Chemie International Edition* 55 (2016) 3862–3881.

- 1 [20] A.K. Au, W. Lee, A. Folch, Mail-order microfluidics: evaluation of stereolithography
2 for the production of microfluidic devices, *Lab on a Chip* 14 (2014) 1294–1301.
- 3 [21] P.J. Bártolo, *Stereolithography: Materials, Processes and Applications*, Springer
4 Science & Business Media, New York, 2011.
- 5 [22] C. Polzin, S. Spath, H. Seitz, Characterization and evaluation of a PMMA-based 3D
6 printing process, *Rapid Prototyping Journal* 19 (2013) 37–43.
- 7 [23] R.M. Frizzarin, E. Aguado, L.A. Portugal, D. Moreno, J.M. Estela, F.R.P. Rocha, V.
8 Cerdà, A portable multi-syringe flow system for spectrofluorimetric determination of iodide
9 in seawater, *Talanta* 144 (2015) 1155–1162.
- 10 [24] V. Cerdà, J. Avivar, D. Moreno, Chips: How to build and implement fluidic devices in
11 flow based systems, *Talanta*, 166 (2017) 412-419.
- 12 [25] R.M. Dagnall, T.S. West, P. Young, Determination of lead with 4-(2-pyridylazo)-
13 resorcinol, *Talanta* 12 (1965) 583–588.
- 14 [26] C. Mitani, A.N. Anthemidis, On-line liquid phase micro-extraction based on drop-in-plug
15 sequential injection lab-at-valve platform for metal determination, *Analytica Chimica Acta* 771
16 (2013) 50-55.
- 17 [27] B. Beltran, L. O. Leal, L. Ferrer, V. Cerda, Determination of lead by atomic fluorescence
18 spectrometry using an automated extraction/pre-concentration flow system, *Journal of*
19 *Analytical Atomic Spectrometry* 30 (2015) 1072-1079.
- 20 [28] M. S. Di Nezio, M. E. Palomeque, B. S. Fernandez Band, A sensitive spectrophotometric
21 method for lead determination by flow injection analysis with on-line preconcentration, *Talanta*
22 63 (2004) 405-409.
- 23 [29] A. N. Anthemidis, K.-I. G. Ioannou, On-line sequential injection dispersive liquid-liquid
24 microextraction system for flame atomic absorption spectrometric determination of copper and
25 lead in water samples, *Talanta* 79 (2009) 86-91.

1 [30] P. Ampan, J. Ruzicka, R. Atallah, G.D. Christian, J. Jakmunee, K. Grudpan, Exploiting
2 sequential injection analysis with bead injection and lab-on-valve for determination of lead using
3 electrothermal atomic absorption spectrometry, *Analytica Chimica Acta* 499 (2003) 167-172.

4 [31] R.B.R. Mesquita, S.M.V. Fernandes, A.O.S.S. Rangel, A flow system for the
5 spectrophotometric determination of lead in different types of waters using ion-exchange for
6 pre-concentration and elimination of interferences, *Talanta* 62 (2004) 395-401.

7

8

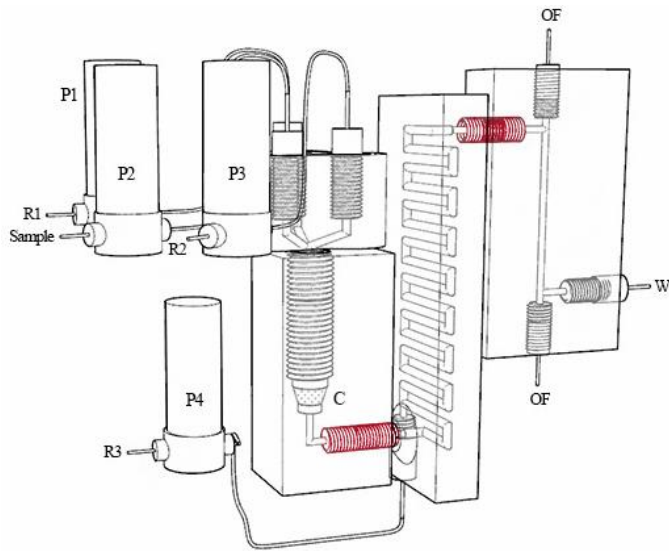

1

2 **Fig. 1.** Schema of the MPFS system with the three 3D printed units. C: resin column, R1: nitric
3 acid, R2: ammonium oxalate, R3: PAR, OF: optical fiber, W: waste. In red, the screws and
4 corresponding screw threads to assemble the units.

5

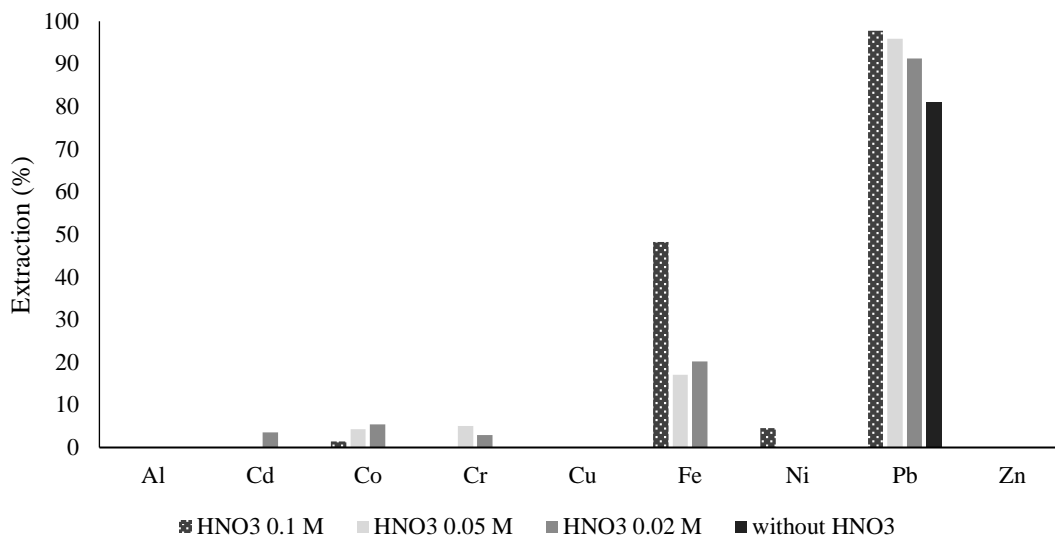

1

2 **Fig. 2.** Extraction of several metals on TrisKem Pb resin for different concentrations of nitric
 3 acid [multi-metal solution at $0.037 \text{ mmol.L}^{-1}$ ($V = 30 \text{ mL}$ at 3 mL.min^{-1}), nitric acid at 5 mL.min^{-1}
 4 ($V = 9 \text{ mL}$ for conditioning step, $V = 6 \text{ mL}$ for washing step), ammonium oxalate at 0.1 mol.L^{-1}
 5 ($V = 10 \text{ mL}$ at 4 mL.min^{-1}).

6

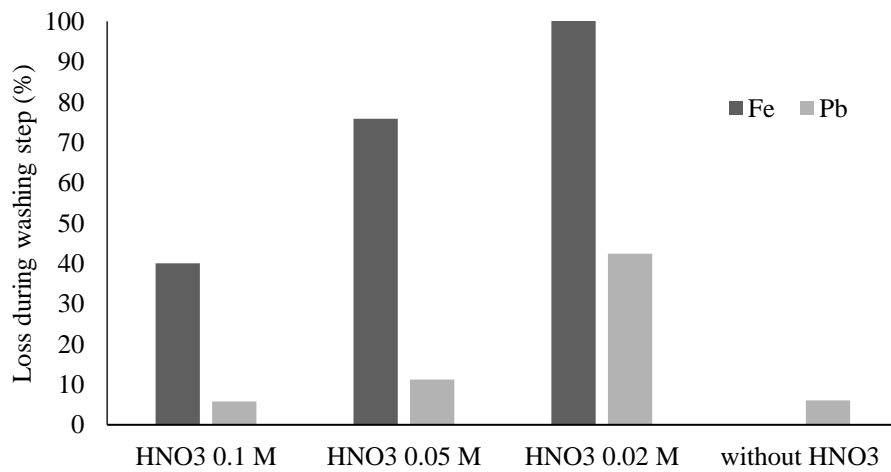

1

2 **Fig. 3.** Iron and lead washing out during washing step [multi-metal solution at 0.037 mmol.L⁻¹
 3 (V = 30 mL at 3 mL.min⁻¹), nitric acid at 5 mL.min⁻¹ (V = 9 mL for conditioning step, V = 6
 4 mL for washing step), ammonium oxalate at 0.1 mol.L⁻¹ (V = 10 mL at 4 mL.min⁻¹).

5

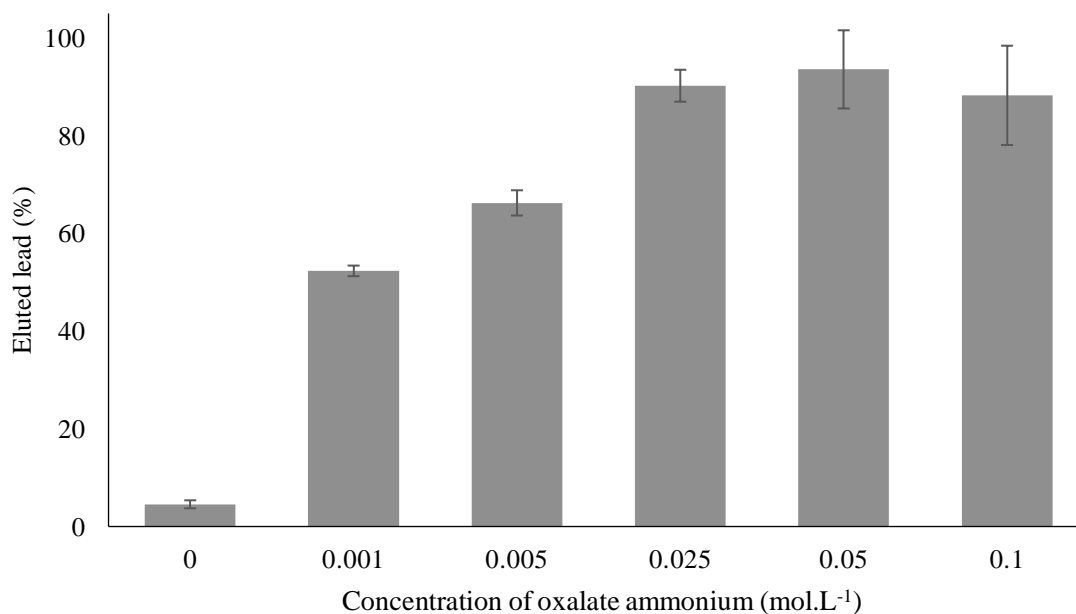

1

2 **Fig. 4.** Elution of lead at different concentrations of ammonium oxalate [lead solution at 100
3 $\mu\text{g.L}^{-1}$ ($V = 30 \text{ mL}$ at 5 mL.min^{-1}), nitric acid at 0.05 mol.L^{-1} ($V = 9 \text{ mL}$ for conditioning step,
4 $V = 6 \text{ mL}$ for washing step, at 5 mL.min^{-1}), ammonium oxalate at 4 mL.min^{-1} ($V = 10 \text{ mL}$)].

5

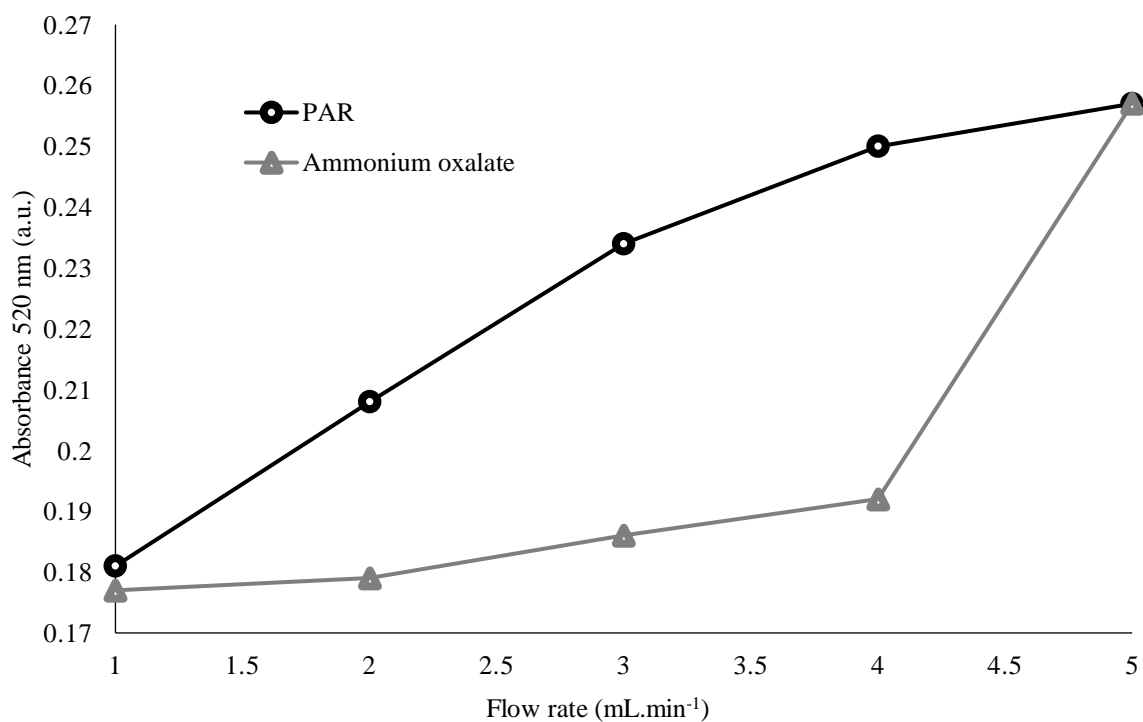

1

2 **Fig. 5.** Absorbance versus PAR and ammonium oxalate flow rates [lead solution at $100 \mu\text{g.L}^{-1}$
3 ($V = 30 \text{ mL}$ at 5 mL.min^{-1}), nitric acid at 0.05 mol.L^{-1} ($V = 9 \text{ mL}$ for conditioning step, $V = 6$
4 mL for washing step, at 5 mL.min^{-1}), ammonium oxalate at 0.025 mol.L^{-1} ($V = 10 \text{ mL}$), PAR
5 at 0.01 mmol.L^{-1} ($V = 10 \text{ mL}$)].

6

1 **Table 1** Flow procedure for lead determination in water

Step	Description	Action	Volume (mL)	Flow-rate (mL.min⁻¹)	P1	P2	P3	P4
1	Conditioning	Pumping nitric acid	9	5	ON	OFF	OFF	OFF
2	Pb extraction	Pumping sample	50	5	OFF	ON	OFF	OFF
3	Washing	Pumping nitric acid	6	5	ON	OFF	OFF	OFF
4	Start data acquisition	-	-	-				
5	Elution & detection	Pumping ammonium oxalate and PAR	5	4	OFF	OFF	ON	ON
6	Stop data acquisition	-	-	-				

2

3

1 **Table 2** Comparison of flow methods for lead determination in water samples.

2

Reference	Flow technique ^a	Preconcentration mode ^b	Detection system ^c	Linear range ($\mu\text{g}\cdot\text{L}^{-1}$)	Precision (%)	LOD ($\mu\text{g}\cdot\text{L}^{-1}$)
[26]	SI-LAV	LPME	FAAS	6 – 300	2.9	1.8
[27]	LOV	SPE	HG-AFS	0.014 – 20	2.4	0.004
[28]	FIA	SPE	Vis	25 – 250	4.5	5
[29]	SI	DLLME	FAAS	2.3 – 160	1.9	0.54
[30]	SI-LOV	BI	ETAAS	2 – 8	1.9	0.6
[31]	SI	SPE	Vis	50 – 300	4	25
Present work	MPFS	SPE	Vis	3 – 120	5.4	2.7

3

4 ^a MPFS: multipumping flow system; SI-LAV: sequential injection – lab-at-valve; LOV: lab-
 5 on-valve; FIA: flow injection analysis; SI : sequential injection; SI-LOV: sequential injection
 6 – lab-on-valve

7 ^b LPME : liquid phase micro-extraction ; SPE : solid phase extraction ; DLLME: dispersive
 8 liquid-liquid micro-extraction; BI: bead injection

9 ^c FAAS: flame atomic absorption spectrometry; Vis: visible spectrophotometry; HG-AFS:
 10 hydride generation-atomic fluorescence spectroscopy; ETAAS: electrothermal atomic
 11 absorption spectrometry

12

13

1 **Table 3** Lead determination in real natural water samples with optimised 3D-printed flow
2 system vs reference method (ICP-AES).

Samples	Lead concentration ($\mu\text{g/L}$)	
	ICP-AES	3D system
Industrial zone (electronic manufacturing) (upstream)	17.4 ± 1.6	15.8 ± 2.5
Industrial zone (electronic manufacturing) (downstream)	15.1 ± 0.8	13.8 ± 1.5
WWTP (upstream)	16.5 ± 1.8	18.7 ± 2.1
WWTP (direct downstream)	17.4 ± 2.2	16.6 ± 0.8
River – (12km downstream)	12.9 ± 0.4	11.6 ± 1.4

3

4